

WINGCO[®] INC

HPS9000VE/E

INSTALLATION AND OPERATORS MANUAL



TRI-FUEL GENERATOR

SAVE THESE INSTRUCTIONS

This manual contains important instructions that should be followed during installation and maintenance of the generator and battery. Read and understand all instructions in the manual before starting and operating the generator set.

USING THE MANUAL

Congratulations on your choice of a Winco generator set. You have selected a high-quality, precision engineered generator set designed and tested to give you years of satisfactory service.

To get the best performance from your new engine generator set, it is important that you carefully read and follow the operating instructions in this manual.

Should you experience a problem please follow the "Troubleshooting Tables" near the end of this manual. The warranty listed in the manual describes what you can expect from WINCO should you need service assistance in the future.

TABLE OF CONTENTS

INTRODUCTION	2
BASIC INFORMATION	
Specifications	2
SAFETY INFORMATION	3
UNIT CAPABILITIES	4
PREPARING THE UNIT	
Unpacking the Unit	5
LP/NG Installation	6
Fuel Line Sizing	7
Fuel Consumption	7
Fuel Pressure	7
Changing Fuel Types	8
Battery Installation	9
INITIAL START UP	
Basic Operation	10
Manual Starting (Gasoline only)	10
Electric Starting (Gasoline)	10
Electric Starting (LP/NG)	11
Stopping & Storage	11
Operating Speed	12
CONNECTING THE LOADS	12
Wiring	13
ENGINE CARE	14
GENERATOR CARE	15
TROUBLESHOOTING	16
CONTROL PANEL WIRING DIAGRAM	17
WARRANTY INFORMATION	18

PROPER USE AND INSTALLATION

You must be sure your new engine generator set is:

- * Properly serviced before starting.
- * Operated in a well ventilated area.
- * Properly exhausted and gases safely dispersed.
- * Operated only for its designed purposes.
- * Used only by operators who understand its operation.
- * Properly maintained.

COPY YOUR MODEL AND SERIAL NUMBER HERE

No other WINCO generator has the same serial number as yours. It is important that you record the number and other vital information here. If you should ever need to contact us on this unit it will help us to respond to your needs faster.

MODEL **HPS9000VE/E**

SERIAL NUMBER _____

PURCHASE DATE _____

DEALER _____

DEALER PHONE # _____

UNIT SPECIFICATIONS

GENERATOR MODEL	HPS9000VE
Surge Watts	9,000
Continuous Watts	8,000
Volts	120/240
Amps	67/33
Engine	Briggs and Stratton 305447-0003-G1
Generator	Mecc Alte Spa S20W-110/

SAFETY INFORMATION

This engine generator set has been designed and manufactured to allow safe, reliable performance. Poor maintenance, improper or careless use can result in potentially deadly hazards; from electrical shock, exhaust gas asphyxiation, or fire. Please read all safety instructions carefully before installation or use. Keep these instructions handy for future reference. Take special note and follow all warnings on the unit labels and in the manuals.

ANSI SAFETY DEFINITIONS

DANGER:

DANGER indicates an imminently hazardous situation which, if not avoided, will result in death or serious injury. This signal word is to be limited to the most extreme situations.

WARNING:

WARNING indicates a potentially hazardous situation which, if not avoided, could result in death or serious injury.

CAUTION:

CAUTION indicates a potentially hazardous situation which, if not avoided, may result in minor or moderate injury. It may also be used to alert against unsafe practices.

1. ELECTRICAL SHOCK The output voltage present in this equipment can cause fatal electric shock. This equipment must be operated by a responsible person.

- a. Do not allow anyone to operate the generator without proper instruction.
- b. Guard against electric shock.
- c. Avoid contact with live terminals or receptacles.
- d. Use extreme care if operating this unit in rain or snow.
- e. Use only three-pronged grounded receptacles and extension cords.
- f. Be sure the unit is properly grounded to an external ground rod driven into the earth.

2. FIRE HAZARD Gasoline and other fuels present a hazard of possible explosion and/or fire.

- a. Do not refuel when the engine is running or hot.

- b. Keep fuel containers out of reach of children.
- c. Do not smoke or use open flame near the generator set or fuel tank.
- d. Keep a fire extinguisher nearby and know its proper use. Fire extinguishers rated ABC by NFPA are appropriate.
- e. Store fuel only in an approved container, and only in a well ventilated area.
- f. Follow local codes for closeness to combustible material.

3. DEADLY EXHAUST GAS Exhaust fumes from any gasoline engine contain carbon monoxide, an invisible, odorless and deadly gas that must be mixed with fresh air.

- a. Operate only in well ventilated areas.
- b. Never operate indoors including attached garages
- c. Never operate the unit in such a way as to allow exhaust gases to seep back into closed rooms (i.e. through windows, walls, floors).

4. NOISE HAZARD Excessive noise is not only tiring, but continual exposure can lead to loss of hearing.

- a. Use hearing protection when working around this equipment for long periods of time.
- b. Keep your neighbors in mind when using this equipment.

5. CLEANLINESS Keep the generator and surrounding area clean.

- a. Remove all grease, ice, snow or materials that create slippery conditions around the unit.
- b. Remove any rags or other materials that could create a potential fire hazard.
- c. Carefully clean up any gas or oil spills before starting the unit.

6. SERVICING EQUIPMENT All service, including the installation or replacement of service parts, should be performed only by a qualified technician.

- a. Use only factory approved repair parts.
- b. Do not work on this equipment when fatigued.
- c. Never remove the protective guards, covers, or receptacle panels while the engine is running.
- d. Use extreme caution when working on electrical components. High output voltage from this equipment can cause serious injury or death.
- e. Always avoid hot mufflers, exhaust manifolds, and engine parts. They can cause severe burns instantly.
- f. The use of the engine-generator set must comply with all national, state, and local codes.

TESTING POLICY

Before any generator is shipped from the factory, it is fully checked for performance. The generator is loaded to its full capacity, and the voltage, current and frequency are carefully checked.

Rated output of generator is based on engineering tests of typical units, and is subject to, and limited by, the temperature, altitude, fuel, and other conditions specified by the manufacturer of the applicable engines.

INTENDED USES

This engine generator set has been designed primarily for portable heavy duty commercial use. Both 120 volt and 240 volt receptacles are provided in the control panel to plug in your loads (lights, portable tools, and small appliances). These units are dual wound generators, therefore the 120 volt loads must be equally split with 1/2 of the rated capacity available on each of the two 120 volt circuits.

This portable unit requires large quantities of fresh air for cooling the engine and generator. For safety, long life and adequate performance, these units should never be run in small compartments without positive fresh air flow.

RESTRICTED USES

DO NOT remove from the cradle assembly. Removal of the generator from the cradle assembly may cause excessive vibration and damage to the engine-generator set.

DO NOT install and operate this generator in a small compartment., i.e. generator compartments of vehicles, motor homes or travel trailers. These compartments will not allow enough free flow of fresh air to reach the engine generator set for cooling and will cause the unit to overheat, damaging both the engine and generator. Small compartments will also develop hot spots where there is very little air flow and may cause a fire.

PLEASE NOTE There are 3rd party companies making enclosures for generators that have been properly engineered. The use of these 3rd party enclosures is acceptable as long as they have been certified and meet current code.

DO NOT attempt to operate at 50 cycles. These units are designed and governed to operate at 60 cycles only.

UNIT CAPABILITIES

GENERATOR CONNECTIONS

HPS9000VE: 120 volt and 240 volt receptacles are provided for connection to various loads. The diagram below represents this 8,000 watt (rated output) generator. A & B represent the 120 volt output legs of this generator. Up to 4000 watts at 120 volts (33 Amps) can be drawn from the receptacles attached to either A or B output legs. This generator is capable of producing 33 Amps of 240 volt current at C. Check the appliance or tool nameplates for the current and voltage to insure compatibility. Remember that power taken from C reduces the power available at equally both A and B and vice versa.

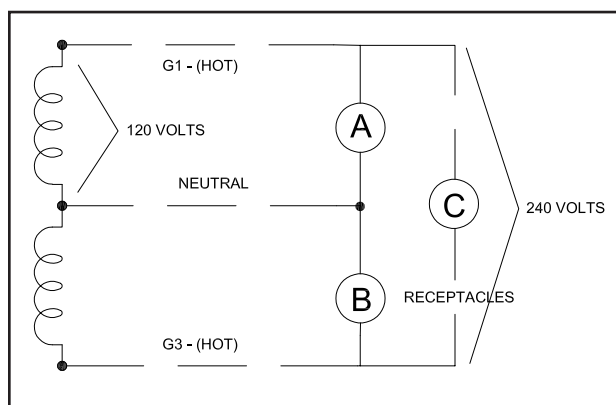

STARTING ELECTRIC MOTORS

Electric motors require much more current (amps) to start them than to run them. Some motors, particularly low cost split-phase motors, are very hard to start and require 5 to 7 times as much starting current as running current. Capacitor motors are easier to start and usually require 2 to 4 times as much starting current as running current. Repulsion Induction motors are the easiest to start and require only 1 1/2 to 2 1/2 times as much starting as running current.

Most fractional horsepower motors take about the same amount of current to run them whether they are Repulsion Induction (RI), Capacitor (Cap), or Split-Phase (SP) type.

If the electric motor is connected to a hard starting load such as an air compressor, it will require more starting current. If it is connected to a light load, or no load such as a power saw, it will require less starting current. The exact requirement will also vary with the brand or design of the motor.

Self-exciting generators respond to severe overloading differently than utility power. When overloaded, the engine is not able to supply enough power to bring the electric motor up to operating speed. The generator responds with high initial starting current, but the engine speed drops sharply. The overload may stall the engine. If allowed to operate at very low speeds, the electric motor starting winding will burn out in a short time. The generator winding might also be damaged.

CAUTION: EQUIPMENT DAMAGE

RUNNING THE GENERATOR SET UNDER THESE CONDITIONS MAY RESULT IN DAMAGE TO THE GENERATOR STATOR AS WELL AS THE MOTOR WINDING.

The heavy surge of current required for starting motors is required for only an instant. The generator will not be damaged if it can bring the motor up to speed in a few seconds of time. If difficulty is experienced in starting motors, turn all other electrical loads off and if possible reduce the load on the electric motor.

PREPARING THE UNIT

UNPACKING

CAUTION: EQUIPMENT DAMAGE

THIS UNIT HAS BEEN SHIPPED WITHOUT OIL. Failure to maintain the engine oil at the proper level will result in serious engine damage.

When you unpack your new engine-generator set be sure to remove all the information sheets and manuals from the carton.

1. This generator-set was in good order when shipped. Inspect the generator-set promptly after receiving it. If any damage is noted, notify the transportation company immediately; request proper procedures for filing a “concealed damage” claim. Title to the equipment and responsibility for filing a claim rests with you when a generator-set is sent F.O.B. shipping point. Only you can legally file a claim.

2. Before proceeding with the preparations of your new generator-set for operation, take a couple of minutes to insure the unit you have received is the correct model and review the specification pages in this manual to insure that this unit meets your job requirements.

LUBRICATION

Before starting the engine, fill the crankcase to the proper level with a good quality oil. The recommended grade of oil and quantity of oil required is listed in the engine operator’s manual and under the service tab in this manual. This unit was shipped with most of the oil removed. The engine normally holds 46 to 48 ounces of oil. Since there is some trapped oil in the engine, when filling the crankcase the first time use the dipstick (ref “A”) to ensure that you do not over fill the crankcase. Reference “B” shows the full oil level mark on the dipstick.

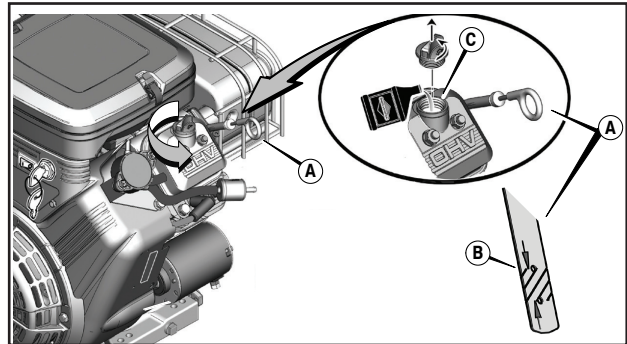

Oil is added to the engine by removing the oil fill cap (ref “C”) and adding oil at this point. After filling the crankcase to the proper level, be sure you properly tighten the oil fill cap. NOTE: This engine generator must be on a level surface before you check or add oil to the system.

The necessity of using the correct oil, and keeping the crankcase full cannot be overemphasized. Engine failures resulting from inadequate or improper lubricant are considered abuse and not covered by the generator or engine manufacturer’s warranty.

Oil Recommendations

Outdoor temperatures determine the proper oil viscosity for the engines. Use the chart to select the best viscosity for the outdoor temperature range expected.

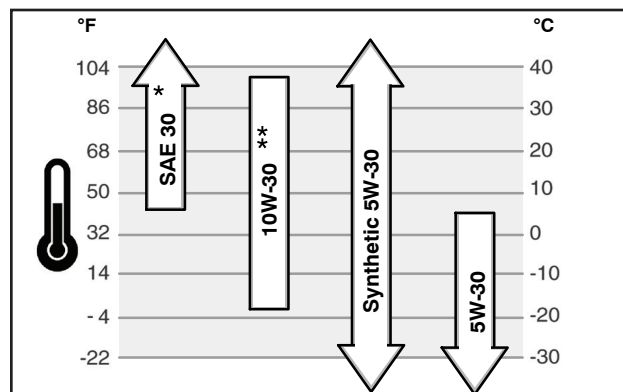

Oil Recommendations Con't

* Below 40°F (4°C) the use of SAE30 will result in hard starting.

** Above 80°F (27°C) the use of 10W-30 may cause increased oil consumption. Check oil level more frequently.

Briggs & Stratton recommends the use of their warranty certified oils for best performance. Other high-quality detergent oils are acceptable if classified for service SF, SG, SH SJ or higher. Do not use special additives.

GASOLINE

When using gasoline, always use fresh, clean, unleaded fuel. This engine is certified to operate on unleaded gasoline with a minimum octane rating of 87 or higher. Gasoline containing no more than 10% ethanol is acceptable.

CAUTION: EQUIPMENT DAMAGE

Do not use unapproved gasolines, such as E15 or E85. Do not mix oil in the gasoline. Use of unapproved fuels will damage the engine components and void the engine warranty.

Use of fuels with content of ethanol greater than shown above may cause starting and/or performance problems. Always insure that the fuel is clean and free of all impurities.

WARNING: FIRE DANGER

Gasoline and its fumes are VERY explosive when proper precautions are not taken.

Never use gasoline that has been stored for an extended period of time as the fuel will lose its volatile properties and you will be left with varnish residue. The varnish like substance will clog the carburetor and will not burn properly.

The use of fuel additives, such as STA-BIL, or an equivalent will minimize the formation of fuel gum deposits. If a unit has been out of operation for an extended period of time, it is best to drain old fuel from the engine and replace with fresh fuel before attempting to start.

See the engine manual for special instruction for operating this unit at over 5000 feet

LP/NG FUEL INSTALLATION

The information in this instruction is offered to assist you in providing the proper vapor fuel supply for your engine. This information is only provided to advise you of the engine's requirements and the decisions you must make. In no case should this information be interpreted to conflict with any local, state or national code. If in doubt, always follow local codes.

DANGER: FIRE - PERSONAL INJURY -

All fuel lines must be installed by a qualified fuel supplier.

The fuel source should be as close as possible to the outdoor operating location. This will reduce the installation cost of fuel runs. Connect the fuel supply line to the inlet of the fuel demand regulator on the unit using a locally approved flexible fuel line (see table for recommended line size). **The pressure supplied to the demand regulator must be FOUR TO SIX OUNCES or 7 to 11 INCHES W.C. (water column).** The primary regulator at the fuel supply must be capable of delivering the proper volume of fuel at this pressure.

Have your local fuel supplier install a protected fuel connection at the outside operating location. He should also install a lockable fuel shut off valve at the connection point. Have your fuel supplier permanently install a flexible fuel line to the demand regulator on the engine generator set.

DANGER: FIRE - PERSONAL INJURY -

The LP/NG fuel supply line must always be shut off when the engine is not running. Failure to do so may allow fuel to leak at the unit.

INSTALLING THE FUEL LINE

DANGER: PERSONAL INJURY

*Units that are intended to be run unattended **MUST** have an electric fuel solenoid installed. This solenoid **MUST** be wired to **AUTOMATICALLY** turn off the fuel whenever the engine stops.*

Unit location will determine the size of fuel line that is required to supply the engine with a constant fuel pressure. Refer to the tables below for fuel line size, and recommended tank size. For distances of 100 feet and over, a two regulator fuel system is recommended. This system consisting of a primary 10-15# regulator at the tank and a 6 ounce secondary regulator installed about 10 feet from the generator.

You need to run a 3/4 inch line or larger from the secondary regulator to the engine-generator set. When a two (2) regulator fuel system is used, a fuel line size of 3/8 inch is generally adequate for distances up to 300 feet. The line size from the table below applies to the distance from the second regulator to the demand regulator. **A positive fuel shut-off device must be installed in the fuel line close to the engine generator set.** This may be either a lockable manual shut-off valve available from your local fuel installer, or a 12 volt DC fuel solenoid valve. This optional 12 volt DC valve is available through your local Winco dealer.

The fuel line used to connect the supply line to the demand regulator must be a locally approved flexible fuel line. Products used will vary in different regions depending on availability and local codes. Consult with your local fuel supplier to insure complete compliance with ALL codes.

1. Remove the pipe plug from the demand regulator.
2. Connect the flex fuel line to the demand regulator to the optional fuel solenoid..

DANGER: PERSONAL INJURY

Do not use galvanized pipe in the fuel line runs. The galvanized coating will become eroded and flake off, causing possible obstruction or damage to the regulator or fuel valve. The obstruction could cause an inoperative engine or an explosive fuel leak.

Size of pipe required for generators operating on natural gas/LP gas.

<u>Length of Fuel Line*</u>	<u>Fuel Line Size</u>
less than 25 feet	3/4 inch black pipe
25 to 100 feet	1 inch black pipe
over 100 feet	not recommended**

*allow an additional 3 feet for each standard elbow.

Do not use 'street ells' (restrictive)

** Consult factory for fuel runs over 100 feet.

DANGER! - FIRE - PERSONAL INJURY -

Be careful when sealing gas joints. Excessive sealing compound can be drawn into the solenoid, regulator or carburetor causing an engine malfunction or dangerous fuel leak.

FUEL CONSUMPTION (Full Load)

Gasoline	1.63Gal/HR	
LP Vapor	1.9 Gal/HR	173,850 BTU
Natural Gas	180 cu ft/hr	180,000 BTU

FUEL PRESSURE

Correct fuel pressure cannot be stressed enough. The most common cause for inoperative systems is an inadequate or incorrect fuel pressure. Power and performance of the engine is in direct relation to the correctness of the fuel system. Shown below is a block diagram of a typical L.P. or N.G. installation.

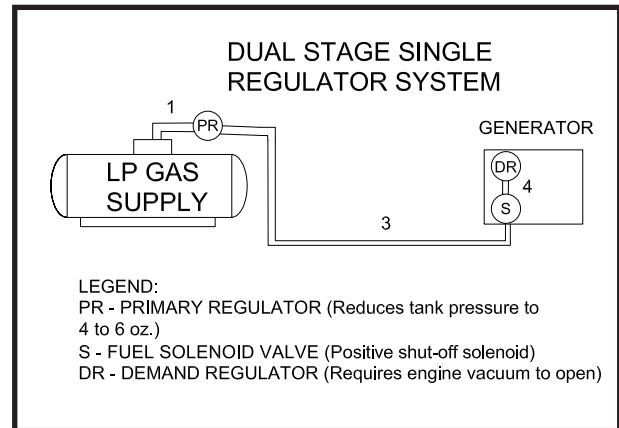

Reference numbers 1 through 3 in the block diagrams above are system parts supplied by customer.

Reference number 4 is the engine generator set.

Below is a table of the fuel pressure reading at each reference in the system.

Fuel Pressure Table

Single Regulator (L.P. Vapor only)

	1	3	4
UNIT OFF	TANK PSI	7-11 in	7-11 in
		4-6 oz	4-6 oz
STARTING	TANK PSI	7-11 in	7-11 in
		4-6 oz	4-6 oz
NO LOAD	TANK PSI	7-11 in	7-11 in
		4-6 oz	4-6 oz
FULL LOAD	TANK PSI	7-11 in	7-11 in
		4-6 oz	4-6 oz

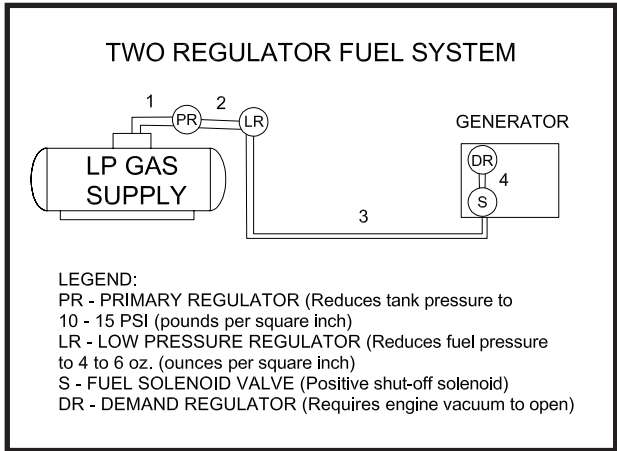

must be between 4 and 6 oz. (7-11 inches of water column). Any lower pressure and the unit will starve for fuel under load. Any higher and the unit will 'flood' when attempting to start.

LP TANK SIZING

Once above the minimum acceptable size, the size of L.P. tank used will generally depend on how long you want the unit to run without refilling. The tank sizes shown below are the smallest recommended tank sizes based on the outside temperature. Keep in mind the colder it gets the slower L.P. will vaporize. This is the reason for the larger tanks at low temperature. Minimum sizing is not based on running time.

Two (2) Regulator System (L.P. Vapor only)

	1	2	3	4
UNIT	TANK	10-15 lbs	7-11 in	7-11 in
OFF	PSI		4-6 oz	4-6 oz
STARTING	TANK	10-15 lbs	7-11 in	7-11 in
	PSI		4-6 oz	4-6 oz
NO LOAD	TANK	10-15 lbs	7-11 in	7-11 in
	PSI		4-6 oz	4-6 oz
FULL	TANK	10-15 lbs	7-11 in	7-11 in
LOAD	PSI		4-6 oz	4-6 oz

Temp f.	60 deg	30 deg	0 deg	-20 deg
	150 gal	250 gal	500 gal	1000 gal

CHANGING FUEL TYPES

These engine generator sets are designed to run on three different fuels; gasoline, natural gas or LP vapor. They may be easily changed from one fuel to another.

FROM GASOLINE TO LP/NG

1. With the engine running turn off the gasoline fuel valve.
2. Run the engine until it runs out of fuel.
3. Remove the pipe plug from the demand regulator.
4. Install locally approved flexible fuel line.
5. Connect the LP/NG vapor fuel line.
6. This unit have two different hose fittings on the top of the demand regulator. One is for LP and one is for Natural Gas. Make sure the hose is attached to the proper fitting.
7. Turn on the vapor fuel.
8. Start the engine.
9. Apply the load to the generator.

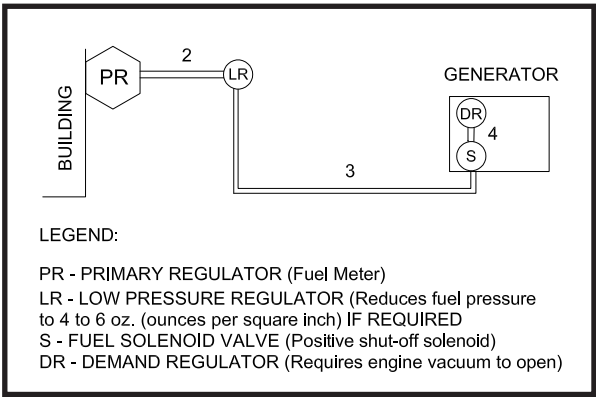

Natural Gas

	1	3	4
UNIT OFF	LINE PSI	7-11 in	7-11 in
		4-6 oz	4-6 oz
STARTING	LINE PSI	7-11 in	7-11 in
		4-6 oz	4-6 oz
NO LOAD	LINE PSI	7-11 in	7-11 in
		4-6 oz	4-6 oz
FULL LOAD	LINE PSI	7-11 in	7-11 in
		4-6 oz	4-6 oz

Remember that whichever fuel delivery system or type of vapor fuel used, the fuel pressure at the demand regulator installed on the engine generator

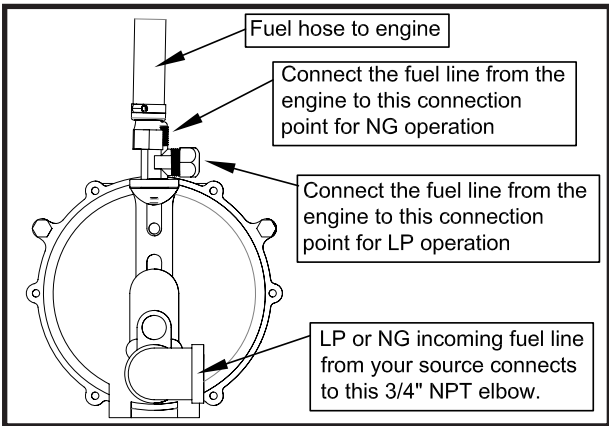

FROM LP/NG TO GASOLINE

1. With the engine running turn off the LP/NG fuel supply.
2. Run the engine until it runs out of fuel.
3. Remove the flexible fuel line from the demand regulator.
4. Reinstall the plastic plug in the regulator.
5. Check to be sure the gasoline fuel valve is off.
6. Fill the gasoline fuel tank.
7. Turn on the gasoline fuel valve.
8. Start the engine.

BATTERY INSTALLATION

This engine generator set is shipped with a battery tie down kit for customer installation. This kit consists of a battery tie down and hardware for installation of the customer supplied battery on the unit. If you intend to use the power plant's electric start system, you will need to purchase and install a battery to operate it. Units equipped with a recoil or rope start will operate satisfactorily on gasoline without a battery but stating on LP/NG requires electric start be used.

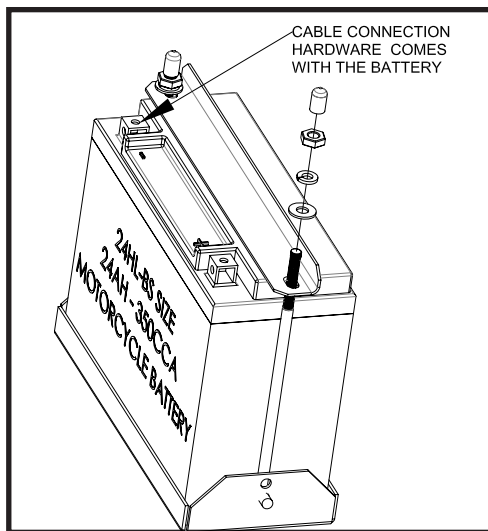

WARNING: EQUIPMENT DAMAGE

The battery positive (+) cable is shipped with a plastic protective cap. When starting manually, this protective cap must remain in place to avoid possible damage to the engine electrical system and/or generator end.

A 12-volt powersports (motorcycle/atv/snowmobile) battery, BCI group 20 or 24HL rated at 300 CCA or larger is recommended for this electric start engine generator set. Maximum length: 8 1/8", Maximum width: 3 9/16", Height range: 5 3/4" - 7".

Amp Hours: 15AH or greater. Follow the battery manufacturers recommendations for servicing and charging prior to use. Connect the battery to the electric start system using the cables provided.

CAUTION: EQUIPMENT DAMAGE

These electric start engines are NEGATIVE GROUND. Use extreme caution when connecting the battery. Connect the NEGATIVE battery terminal to GROUND.

For your safety always connect the positive battery cable to the "bat+" terminal first. Then connect the negative battery cable to the "bat-" terminal. Make sure all connections are clean and tight. Reverse the sequence when disconnecting, disconnect the negative cable first. These engines produce enough direct current to keep a battery charged under normal operating conditions, but were not intended to be used as a battery charger.

WARNING: PERSONAL INJURY

Lead acid batteries produce explosive hydrogen gas when charging. Keep sparks, flames, and burning cigarettes away from the battery. Ventilate the area when charging or using the battery in an enclosed space. Lead acid batteries contain sulfuric acid, which causes severe burns. If acid contacts eyes, skin or clothing, flush well with water. For contact with eyes, get immediate medical attention.

BATTERY CHARGING

Units equipped with electric start have a small flywheel charger built into the engine flywheel assembly for recharging the starting battery. This flywheel charger generates a small AC current that passes through a diode assembly to produce a DC charging current of about 1 to 3 AMPS. This circuit is not designed to be used as a battery charging circuit to recharge dead batteries.

OPTIONAL DOLLY KIT

An optional dolly kit is available for this generator. The dolly kit comes with instructions and parts list. After installing the dolly kit, file the instructions and parts list in the back of this manual for future reference.

OIL ALERT SYSTEM

This WINCO generator is equipped standard with low oil shutdown systems. The Briggs and Stratton engine uses an oil pressure switch system. This low oil warning system will automatically stop the engine before the oil level reaches a critical danger point. This feature is designed to prevent costly repairs and downtime.

CAUTION: EQUIPMENT DAMAGE

Allowing the engine to shutdown repeatedly on low oil level may cause excessive wear which can be cumulative.

INITIAL START UP

The throttle control on these generators is preset and locked to operate at 3600 RPM (nominal) with no load speed set at 3690 RPM. Only a trained service technician should be allowed to adjust this speed setting.

NOTICE: ENGINE START LOCKOUT

*This unit **will not start** if it is low on oil. The lubricating oil level must be at the **full** mark before the engine will start and run.*

BASIC OPERATION

MANUAL STARTING (Gasoline only)

Refer to the engine manual for additional starting, operating, and stopping instructions.

1. Check oil level. Refill as needed

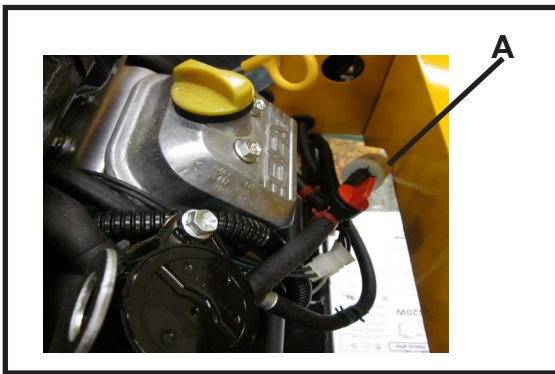

2. Turn on the fuel supply, Ref "A"

NOTE - There is a second fuel valve under the fuel tank that is used when removing the tank. This valve is normally left on.



3. Pull out the choke (Ref "B") to the full "on" position.
4. Turn the key to the run position, Ref "C"
5. Pull the starter grip lightly until resistance is felt, then pull briskly.
6. When the engine starts, open the choke gradually.
7. The engine should promptly come up to operating speed.

NOTICE:

Do not allow the starter grip to snap back against the engine. Return it gently to prevent damage to the starter.

ELECTRIC STARTING (Gasoline only)

If the engine is cold and stiff or if the battery is not fully charged, starting can be made easier by slowly hand cranking the engine through the compression stroke before pushing the starter switch. This permits the starter to gain momentum before the heavy load of the compression stroke occurs. This minimizes the drain on the battery and improves the possibility of starting under such adverse conditions. Always keep the battery charged, especially during cold weather operation.

1. Check oil level, refill as needed
2. Turn on the fuel supply. Ref "A"
3. Move the choke to the full "on" position. A warm engine will require less choking than a cold engine. Ref "B"
4. Rotate the key switch (Ref "C") briefly to the START position. The starter life is improved by using shorter starting cycles with time to cool off between cranking cycles. Do not operate the starter more than 15 seconds during each minute. Repeat if necessary.
5. When the engine starts, open the choke gradually.
6. The engine should promptly come up to operating speed.

CAUTION: EQUIPMENT DAMAGE

Never permit the choke to remain on after the engine has run for a short time. It is not necessary to choke the engine when it is warm. Avoid over-choking.

ELECTRIC STARTING LP/NG only)

When operating on LP or NG, you will have to always use the electric start to get the unit running. Because of the engine vacuum need to activate the fuel system it is almost impossible to manual start the unit using LP or NG.

1. Check oil level, refill as needed.
2. Turn on the LP/NG fuel supply
3. **NEVER USE THE CHOKE WHEN OPERATING ON LP or NG.**



4. Rotate the key switch (Ref "C") briefly to the START position. The starter life is improved by using shorter starting cycles with time to cool off between cranking cycles. Do not operate the starter more than 15 seconds during each minute. Repeat if necessary.
5. When the engine starts, release the key switch, allowing it to return to the "on" position.
6. The engine should promptly come up to operating speed.

STARTING HINTS

1. **Cold weather**
 - a. Use the proper oil for the temperature expected.
 - b. Use fresh winter grade fuel. Winter grade gasoline is blended to improve starting. Do not use summer grade gasoline.
2. **Hot weather**
 - a. Use the proper oil for the temperature expected.
 - b. Use only summer blended gasoline. Using gasoline left over from winter may cause the unit to vapor lock.

STOPPING AND STORAGE

1. Move the on/off switch to the "OFF" position.
2. Before extended storage (over 30 days) certain precautions must be taken to ensure the fuel doesn't deteriorate and clog the fuel system.

Note: The use of a fuel additive, such as Briggs & Stratton Advanced Fuel Treatment & Stabilizer or an equivalent will minimize the formation of gum deposits during storage. The additive may be added to gasoline in the engines fuel tank or to gasoline in a storage container.

- a. Add the fuel stabilizer to the fuel in the tank and run the unit for 2 minutes to circulate the stabilizer throughout the fuel system.
- b. If you choose to remove the remaining fuel from the fuel tank, it must be drained into an approved container.
- c. Start the engine and allow it to run until all the fuel in the carburetor and the fuel lines has been used up and the engine stops.

Note: Running the engine to use up the fuel in the lines and carburetor will still leave a small amount of fuel in the carburetor. It is best for extended storage to treat the fuel before draining.

- d. While the engine is warm, drain the oil and refill with fresh oil.
- e. Clean dirt and chaff from cylinder, cylinder head fins, blower housing, screen and muffler areas.
- f. Store in a clean and dry area.

OPERATING SPEED

The engine-generator must be run at the correct speed in order to produce the proper electrical voltage and frequency.

CAUTION: EQUIPMENT DAMAGE

The output voltage should be checked to insure the generator is working properly prior to connecting a load to the generator. Failure to do so could result in damage to equipment plugged into the unit and possible injury to the individual.

All engines have a tendency to slow down when a load is applied. When the electrical load is connected to the generator, the engine is more heavily loaded, and as a result the speed drops slightly. This slight decrease in speed, together with the voltage drop within the generator itself, results in a slightly lower voltage when the generator is loaded to its full capacity than when running no load. The slight variation in speed also affects the frequency of the output current. This frequency variation has no appreciable effect in the operation of motors, lights and most appliances. However, electronic equipment and clocks will be affected if correct RPM is not maintained. See Load vs. Output chart.

Although individual units and models vary slightly, the normal voltage and frequency of the engine-generator described in this manual are approximately as follows, under varying loads:

LOAD VS. OUTPUT			
Generator Load	Speed (RPM)	Frequency (Hz)	Voltage
None	3690	61.5	125V
Half	3600	60.0	120V
Full	3510	58.5	115V

The speed of the engine was carefully adjusted at the factory so that the generator produces the proper voltage and frequency. For normal usage, the speed setting should not be changed. If the generator is being run continuously on a very light load, it is often advisable to lower the operating speed slightly. Reference "D" below is the speed adjustment for this engine.

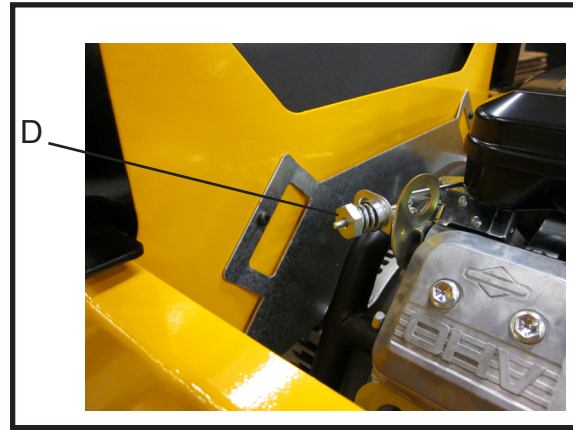

CAUTION: EQUIPMENT DAMAGE

SPEED ADJUSTMENTS SHOULD ONLY BE MADE BY A QUALIFIED SERVICE TECH.
Whenever making any speed adjustments, check the unit with a voltmeter and a frequency meter or tachometer and be sure the voltage and speed are correct.

Lower voltage may damage both the generator and any load connected to it. Running the engine at excessively high speeds results in high voltage, which may significantly shorten the life of appliances being used.

Output voltage should be checked periodically to ensure continued proper operation of the generating plant and appliances. If the generator is not equipped with a voltmeter, it can be checked with a portable meter.

CONNECTING THE LOADS

APPLYING THE LOADS

Allow the engine to warm up for two or three minutes before applying any load. This will allow the engine to reach normal operating temperature and oil to circulate throughout the engine. A short warm-up time will permit the engine to work more efficiently when the load is applied and will reduce the wear in the engine, extending its life.

Receptacles have been provided to allow loads to be connected to the generator. The loads should be added one at a time. If a large motor is being started; or multiple motors are being started, they should be started individually and the largest should be started first.

CAUTION: EQUIPMENT OVERLOAD

Keep the generator load within the generator and receptacle nameplate rating. Overloading may cause damage to the generator and/or the loads .

Most electric tools and appliances will have the voltage and amperage requirements on their individual nameplates. When in doubt, consult the manufacturer or a local electrician. The nameplate amperage rating for electric motors can be misleading. See "Starting Electric Motors" in Unit Capabilities (page 4).

These engine-generator sets are inherently self regulating based on engine speed. The engine governor will automatically adjust itself to the load. No harm to the generator will result if it is operated with no load connected. Proper utilization of the receptacles located on the control panel is necessary to prevent damage to either the receptacles or the generator. The generator is a limited source of electrical power, therefore, pay special attention to the receptacle and generator ratings. The nameplate rating can be obtained through a single receptacle as long as the receptacle amperage rating is not exceeded.

GROUNDING

All units must be grounded. Drive a 3/4 or 1" copper pipe or rod into the ground close to the engine-generator set. The pipe must penetrate moist earth. Connect an approved ground clamp to the pipe. Run a no. 10 Awg wire from clamp to the generator ground lug on the receptacle panel. Do not connect to a water pipe or to a ground used by a radio system. The engine-generators covered in this manual were designed primarily for portable use. If you are connecting into a building wiring system that is already grounded using the 14-60 4 wire plug, you do not have to ground the unit.

WARNING: PERSONAL DANGER

DO NOT OPERATE THIS GENERATOR INDOORS.

The unit should be stored in a warm dry location. During a power outage, move the unit outdoors to a flat dry location such as a driveway or sidewalk.

WIRING

Plug your tools such as drills, saws, blowers, sump pump and other items to be powered directly into the generator receptacles. Before plugging in all the tools and cord sets, recheck the rating of the generator set. Be sure it can handle the intended load and is compatible with the voltage, phase, and current ratings. 'Hard Wiring' this unit directly into a home or a temporary construction site electrical system is **NOT A SIMPLE DO-IT-YOURSELF JOB**. For your safety, all wiring must be done by a qualified electrician and conform to the National Electric Code and comply with all state and local codes and regulations. Check with local authorities before proceeding.

WARNING: PERSONAL DANGER

A fully isolated, double pole double throw manual transfer switch must be installed any time a generator is being connected to an existing distribution system.

1. These engine generator sets are designed for portable use. Receptacles are provided on the control panel to permit 120 volt portable appliances and tools to be plugged directly into them. Please note that the 4-wire 120/240 volt receptacle on these units are designed to power both 120 or 240 volt loads. The plug for this receptacle can be wired for either 120 volt, 240 volt, or a combination of 120 and 240 volt loads depending on how the plug is wired.

A 4-wire receptacle (two hot, one ground, and one neutral) has been provided on the control panel for use in temporary power applications requiring 120/240 volt power. Consult a licensed electrician for wiring the TemPower plug and connecting it as temporary service. To connect these units directly to an un-powered, isolated construction site TemPower panel, have your electrician connect to the control panel using a 120/240 volt, 4-wire twist-lock plug (L14-30P).

2. If the generator set is be connected to an existing distribution system, a fully isolated manual transfer switch must be installed. The transfer switch prevents damage to the generator and other circuit components if main line power is restored while the generator is connected. Installing a transfer switch also permits the use of normal fusing.

3. Many homes and construction sites are wired for at least 60 to 100 Amp entrance service, much greater than the capacity of this portable generator. When installing the generator at these sites, a secondary emergency distribution panel may have to be installed, such as the Emergency Transfer/Service (ET/S) system available through your WINCO dealer. The emergency distribution panel must be installed by a licensed electrician according to all applicable codes. The electrician will move the critical circuits to be powered during the outage to the emergency panel. Keep in mind only a limited amount of amperage is available from the generator set. Some circuit breakers may still have to be turned off to prevent an overload on the generator during the initial start up. See the nameplate on your generator for the amperage capabilities of your unit.

CAUTION: EQUIPMENT DAMAGE

Failure to properly limit and balance the load applied to the generator will cause the generator to produce low voltage and may damage the engine generator set. It may also cause severe damage to the loads connected to the generator at that time. Improper loading of the generator set constitutes abuse and will not be covered by warranty.

ENGINE CARE

Maintenance Chart
First 5 Hours
<ul style="list-style-type: none"> Change oil
Every 8 Hours or Daily
<ul style="list-style-type: none"> Check engine oil level Clean area around muffler and controls
Every 100 Hours or Annually
<ul style="list-style-type: none"> Clean or change air filter * Clean pre-cleaner (if equipped) * Change engine oil and filter Replace spark plug Check muffler and spark arrester
Every 250 Hours or Annually
<ul style="list-style-type: none"> Check valve clearance. Adjust if necessary.
Every 400 Hours or Annually
<ul style="list-style-type: none"> Change air filter Replace fuel filter Clean air cooling system * Clean oil cooler fins *
* In dusty conditions or when airborne debris is present, clean more often.

If major engine service or repair is required, contact an authorized engine service center. The manufacturer of these engines has established an excellent world-wide engine service organization. Engine service is very likely available from a nearby authorized dealer or distributor. Check the yellow pages of your local telephone directory under "Engines-Gasoline" for the closest engine repair center or ask the dealer from whom you purchased the power plant.

1. **Change the oil** after the first 5 hours of operation

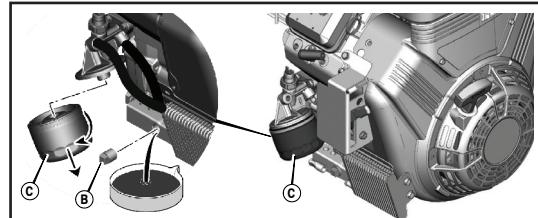

and yearly or 100 hours thereafter under normal operating conditions. Change engine oil every 50 hours of operation if the engine is operated under heavy load, or in high ambient temperatures.

- Start the engine and warm it up, stop the engine and remove the spark plug wire to prevent it from accidentally being started.
- Remove oil drain plug at base of the engine (Ref "B") and drain the oil into an approved container.
- Remove the oil filter (Ref "C") and dispose of it properly.
- Before you install the new oil filter, lightly lubricate the oil filter gasket with fresh clean oil.
- Install the oil filter by hand until the gasket contacts the oil filter adapter, then tighten the oil filter 1/2 to 3/4 turns.
- Replace oil drain plug.
- Remove oil filler plug and refill with new oil. Refer to the table on page 5 for the proper grade of oil based on your operating temperature.

NOTE: This engine requires 46 to 48 ounces of oil if it is completely drained. Use caution when refilling the engine as some residual oil may have remained in the engine. Always use the dipstick when filling the engine with oil to prevent overfilling.

- Replace filler plug.
- Start the engine up and warm it up.
- After warming up the engine, recheck the oil level and refill as necessary to bring it to the proper level. See page 5 for proper oil level.

2. **Checking the Oil Level:** The oil level must always be checked before the engine is started. Take care to remove any dirt or debris from around the oil fill plug before removing. Be sure the oil level is maintained. Fill to the "FULL" mark on the dipstick.

3. **Dual Element Air Filter:** Clean and or replace foam pre-cleaner and air filter annually or every 100 hours. Service more often under dusty conditions.

WARNING: EQUIPMENT DAMAGE

Never start or run the engine with the air filter removed

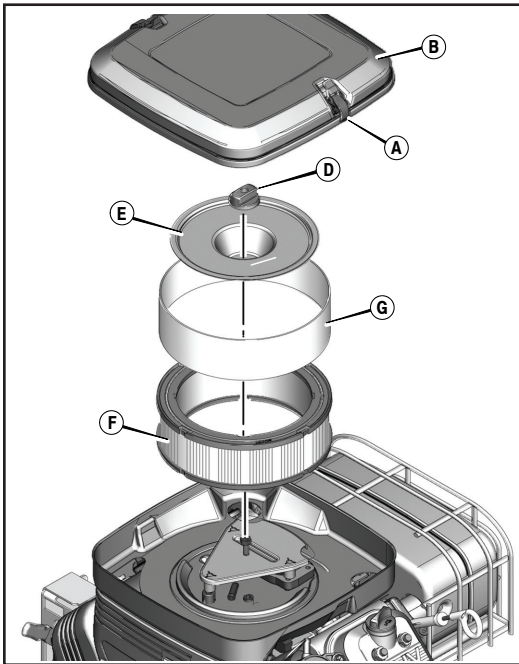

- a. Loosen snaps (Ref "A") and remove cover. Ref "B"
- b. Remove the nut (Ref "D") and the retainer. (Ref "E")
- c. Remove the air filter. (Ref "F")
- d. Remove the pre-cleaner (Ref "G") from the air filter.
- e. To loosen debris, gently tap the air filter on a hard surface. If the air filter is excessively dirty, replace with a new filter.

Notice: Do not use pressurized air or solvents to clean the filter. Pressurized air can damage the filter and solvents will dissolve the filter.

- f. Wash the pre-cleaner in liquid detergent and water. Then allow it to thoroughly air dry.
DO NOT oil the pre-cleaner.
- g. Install foam pre-cleaner to the air filter.
- h. Install the air filter and secure with retainer and nut
- i. Install and secure the cover.

4. **Spark Plug:** Replace annually or every 100 hours of operation. Always replace with the same spark plug that came in the engine and check gap before installing. Spark plug gap is 0.030". Poor spark will also occur if spark plug wire does not fit firmly on spark plug. If this happens, reform the terminal to fit firmly on spark plug tip.

5. **Carbon Canister:** Designed to collect, store, and dispose of fuel vapors created in the fuel tank / fuel system. The canister should last the life of the unit as long as it stays dry.

GENERATOR CARE

Proper care and maintenance of the generator is necessary to ensure a long trouble free life.

1. **Exercising The Generator** - The generator should be operated every three to four weeks. It should be operated for a period of time sufficient to warm the unit up and to dry out any moisture that has accumulated in the windings. If left, this moisture can cause corrosion in the winding. Frequent operation of the engine generator set will also insure that the set is operating properly should it be needed in an emergency.

2. **Generator Maintenance** - Any major generator service, including the installation or replacement of parts, should be performed only by a qualified electrical service technician. **USE ONLY FACTORY APPROVED REPAIR PARTS.**

- a. Bearing - The bearing used in these generators is a heavy duty double sealed ball bearing. They require no maintenance or lubrication.
- b. Receptacles - Quality receptacles have been utilized. If a receptacle should become cracked or otherwise damaged, replace it. Using damaged or cracked receptacles can be both dangerous to the operator and destructive to the equipment.

CLEANING

Remove dirt and debris with a cloth or brush. DO NOT use high pressure spray to clean either the engine or the generator. This high pressure spray could contaminate the fuel system and the generator components.

1. Keep the air inlet screen on both the engine and generator free of any dirt or debris to insure proper cooling. At least yearly, remove the blower housing on the engine and clean the chaff and dirt out of the engine cooling fins and flywheel. Clean more often if necessary. Failure to keep these areas clean may cause overheating and permanent damage to the unit.
2. Periodically clean muffler area to remove all grass, dirt and combustible debris to prevent a fire.
3. On engine mufflers equipped with spark arresters, the spark arrester must be removed every 50 hours for cleaning and inspection. Replace if damaged

TROUBLESHOOTING

PROBLEM (SYMPTOMS) POSSIBLE

CAUSES

Won't Start	<ul style="list-style-type: none"> *Low Oil Level. *Fouled spark plug. *Out of fuel. *Start switch in Off position. *Fuel valve turn off. *Plugged fuel filter.
Voltage too low	<ul style="list-style-type: none"> *Engine speed is too low. *Generator overloaded. *Defective stator. *Defective rotor (field). *Defective Capacitor.
Circuit Breaker Trips	<ul style="list-style-type: none"> *Defective load. *Defective receptacle. *Excessive Load.
Voltage too high	<ul style="list-style-type: none"> *Engine speed is too high.
Generator overheating	<ul style="list-style-type: none"> *Overloaded. *Insufficient ventilation.

No output voltage	<ul style="list-style-type: none"> *Short in load (disconnect). *Tripped or defective circuit breaker. *Broken or loose wire. *Defective receptacle. *No residual magnetism (in generator). *Defective stator. *Defective rotor (field). *Shorted capacitor. *Shorted diodes on rotor. *GFCI Receptacle tripped.
-------------------	--

GENERATOR SPECIFICATIONS

Generator manufacturer	MECC Alte Spa
Generator model number	S20W-110
Part number	16346-006
Rotor resistance	5.22 Ohms
Stator resistance	0.210 Ohms
Cap winding resistance	0.87 Ohms
Capacitors	35 mF
Capacitor part number	16346-312

ENGINE SPECIFICATIONS

Engine manufacturer	Briggs & Stratton
Engine model number	305447
Type & Code	0003-G1
Spark plugs	491055
Air filter	394018
Air filter pre-cleaner	272490
Oil filter 6 cm long	492932
Oil filter 9 cm long	491056
Spark plug gap	0.030 in
Armature air gap	0.008 - 0.012 in
Intake valve clearance	0.004 - 0.006 in
Exhaust valve clearance	0.004 - 0.006 in
Oil capacity	46 - 48 oz.

CONTROL PANEL WIRING DIAGRAM

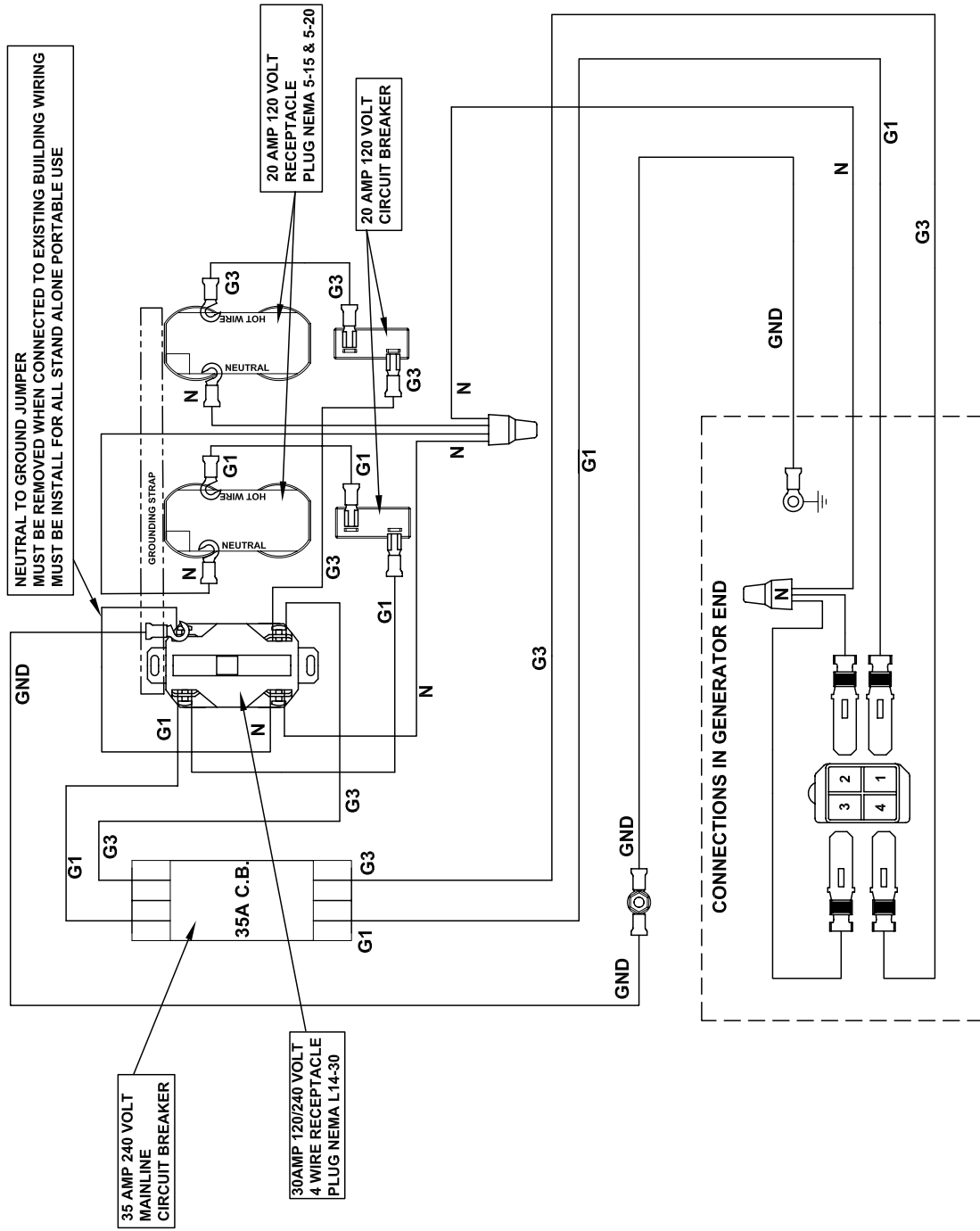



24 MONTH LIMITED WARRANTY

WINCO, Inc. warrants to the original purchaser for 24 months that goods manufactured or supplied by it will be free from defects in workmanship and material, provided such goods are installed, operated and maintained in accordance with **WINCO's** written instructions.

WINCO, Inc. warrants to the ultimate purchaser and each subsequent purchaser that the evaporative emission control system is designed, built, and equipped so as to conform at the time of original sale to the then current evaporative emission requirements. In addition it is free from defects in materials and workmanship that may keep it from meeting these requirements. This evaporative emission control system is warranted for two years. If an evaporative emission related part on your equipment is defective, the part will be repaired or replaced by **WINCO Inc.**

WINCO's sole liability, and Purchaser's sole remedy for a failure under this warranty, shall be limited to the repair of the product. At **WINCO's** option, material found to be defective in material or workmanship under normal use and service will be repaired or replaced. For warranty service, return the product within 24 months from the date of purchase, transportation charges prepaid, to your nearest **WINCO** Authorized Service Center or to **WINCO Inc.** at Le Center, Minnesota.

THERE IS NO OTHER EXPRESS WARRANTY.

To the extent permitted by law, any and all warranties, including those of merchantability and fitness for a particular purpose, are limited to 24 months from date of purchase. In no event is **WINCO** liable for incidental or consequential damages.

Note: Some states do not allow limitation on the duration of implied warranty and some states do not allow the exclusion or limitation of incidental or consequential damages, so the above limitations may not apply in every instance. This warranty gives you specific legal rights which may vary from state to state.

WINCO reserves the right to change or improve its products without incurring any obligations to make such changes or improvements on products purchased previously.

EXCLUSIONS:

WINCO does not warrant Engines. Engines are covered exclusively by the warranties of their respective manufacturers.

WINCO does not warrant Batteries, or Other Component Parts that are warranted by their respective manufacturers.

WINCO does not warrant modifications or alterations which were not made by **WINCO Inc.**

WINCO does not warrant products which have been subjected to misuse and/or negligence or have been involved in an accident.

This warranty does not include travel time, mileage or labor for removal or reinstallation of a **WINCO** product from its application.

CALIFORNIA EVAPORATIVE EMISSION CONTROL WARRANTY STATEMENT YOUR WARRANTY RIGHTS AND OBLIGATIONS

The California Air Resources Board is pleased to explain the evaporative emission control system's warranty on your model 2013 or later generator. In California, new equipment that uses small off-road engines must be designed, built, and equipped to meet the State's stringent anti-smog standards. WINCO must warrant the evaporative emission control system on your generator for the period listed below provided there has been no abuse, neglect or improper maintenance of your equipment.

Your evaporative emission control system may include parts such as: carburetor, fuel tanks, fuel lines, fuel caps, valves, canisters, filters, vapor hoses, clamps, connectors and other associated components.

MANUFACTURER'S WARRANTY COVERAGE

The evaporative emission control system is warranted for two years. If any evaporative emission related parts on your equipment are defective, the parts will be repaired or replaced by WINCO.

OWNER'S WARRANTY RESPONSIBILITIES:

As the generator owner, you are responsible for performance of the required maintenance listed in your owner's manuals. WINCO recommends that you retain all receipts covering maintenance on your generator, but WINCO cannot deny warranty solely for lack of receipts.

As the generator owner, you should be aware that WINCO may deny you warranty coverage if your generator or a part has failed due to abuse, neglect, or improper maintenance or unapproved modifications.

You are responsible for presenting your generator to a WINCO service center as soon as the problem exists. The warranty repairs should be completed in a reasonable amount of time, not to exceed 30 days. If you have a question regarding your warranty coverage, you should contact WINCO at 507-357-6831.

**WINCO INC.
225 S. CORDOVA AVE.
LE CENTER, MN 56057
507-357-6821
SERVICE DEPT.
507-357-6831
www.wincogen.com**